

PRM125D

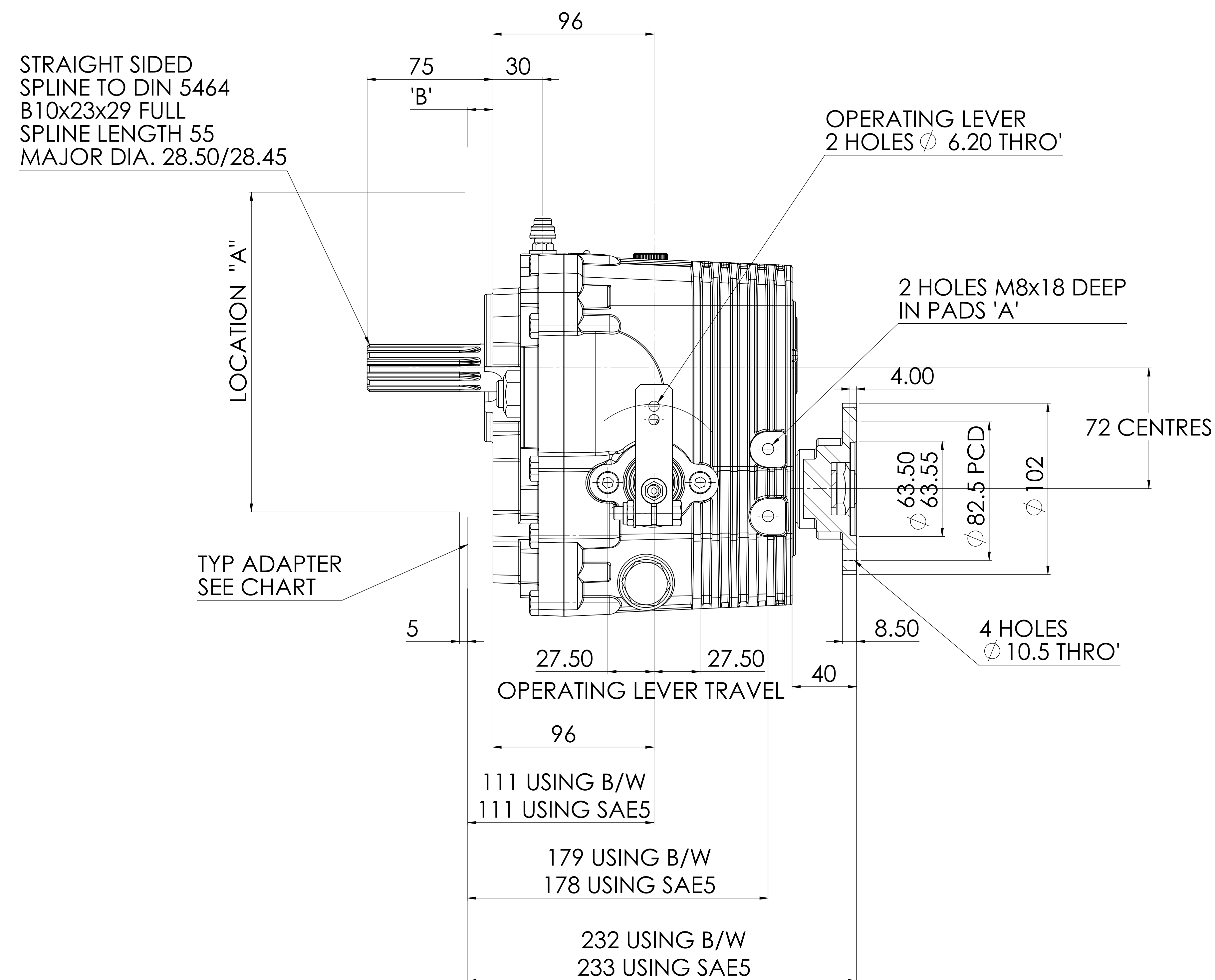
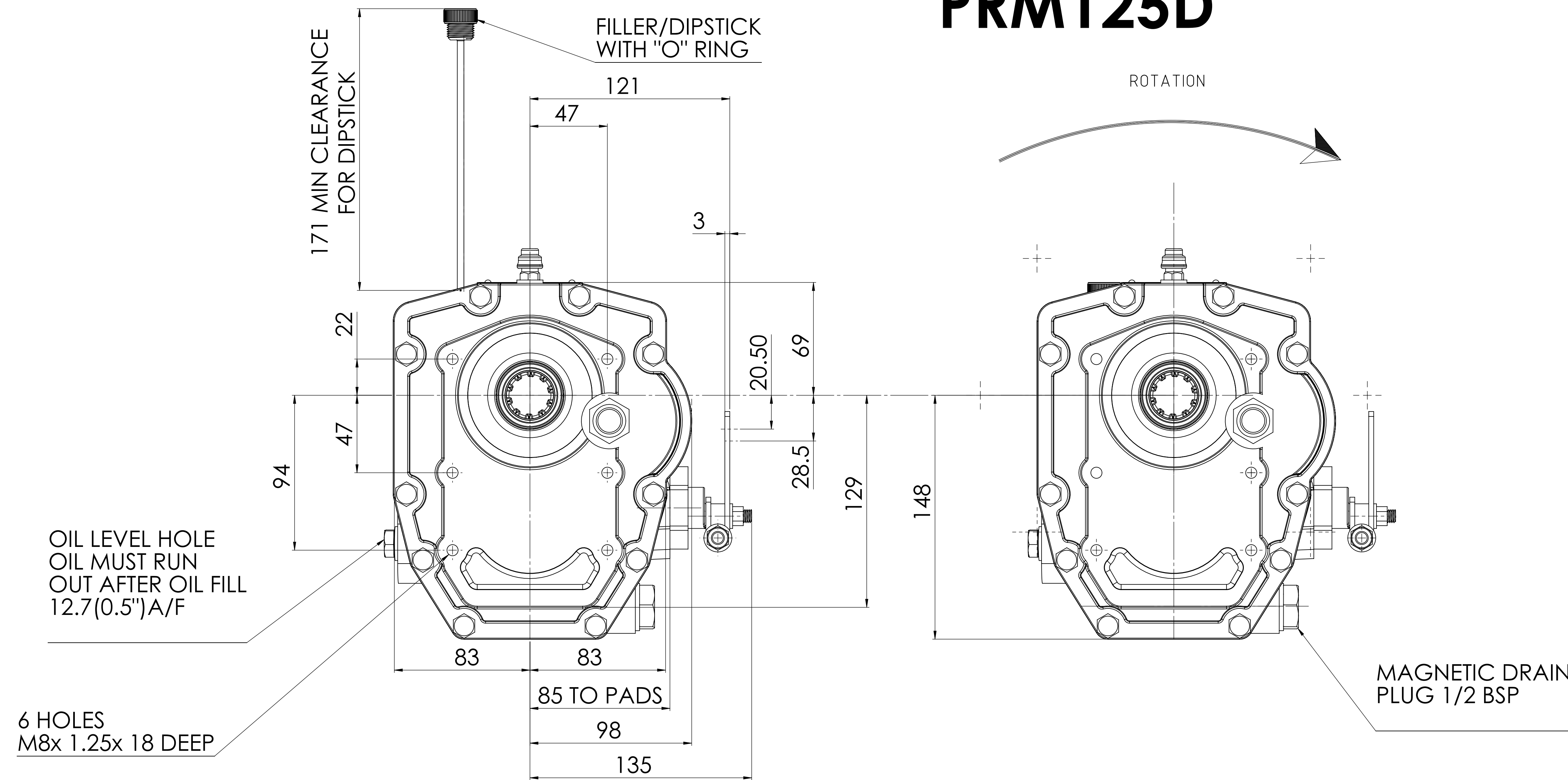

ADAPTORS	ϕ A	B
SAE5	314.33 (12.375")	16.0 (0.63")
B/W	209.55 (8.250")	15.0 (0.591")
SAE4	361.95 (14.25")	19.0 (0.75")

NOTE: MOVE GEAR SELECTOR LEVER FORWARD i.e. TOWARDS GEARBOX INPUT FOR AHEAD AND REARWARDS FOR ASTERN

INSTALLATION ANGLE
The maximum fore and aft installation angle permissible at rest is 15°

IMPORTANT NOTE
All information given in this manual is correct at the time of going to press. However, in the interests of technical progress, design specifications are subject to change without notice. Accordingly, data given herein should be regarded as a general guide only and does not form part of any contract. Any specific performance requirements must be made known to us in writing with customer orders for goods. Illustration are approximate only and do not form part of any contract with us; certified installation drawings are available on request. All goods are supplied in accordance with our standard terms and conditions of sale.